

**Level Best**

**LASER GRADING BOX**

# OPERATORS MANUAL

FOR

**COMPACT - SINGLE**  
**CUSTOMER SUPPLIED LASER CONTROLS**

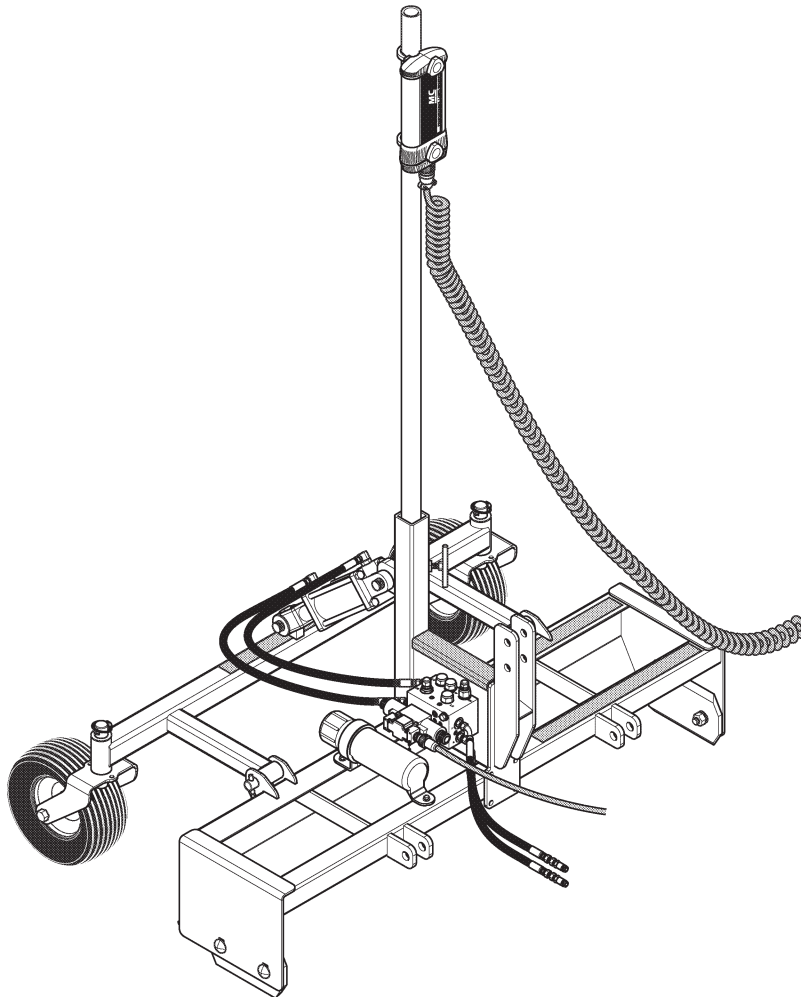

ATI Corporation

New Holland, PA 17557

Phone (717) 354-8721 • FAX (717) 354-2162

1-800-342-0905

[www.level-best.com](http://www.level-best.com)

**JUNE 2008**

CAT.#LBLGBCOM-G-0608



---

**COPYRIGHT 2008 by  
ATI Corporation  
New Holland, PA 17557 U.S.A.**

### **DISCLAIMER**

THE INFORMATION IN THIS MANUAL IS PROVIDED TO PROMOTE THE SAFE USE OF, AND ASSIST THE OPERATOR IN ACHIEVING THE BEST PERFORMANCE FROM, THE PRODUCTS DESCRIBED HEREIN WHEN USED FOR THE INTENDED APPLICATION.

---

## MODELS

---

<b>Part Number</b>	<b>Model Number</b>	<b>Description</b>
315-070-000	SC48	Box, Grader, Tractor, Single, 48", Cylinder Only
315-071-000	SC54	Box, Grader, Tractor, Single, 54", Cylinder Only
315-072-000	SC60	Box, Grader, Tractor, Single, 60", Cylinder Only
315-073-000	SC66	Box, Grader, Tractor, Single, 66", Cylinder Only
315-074-000	SC72	Box, Grader, Tractor, Single, 72", Cylinder Only
000-166-452		Kit, Hydraulic, Single, Apache, Includes Valve Assembly, Hoses, Fittings & Solenoid Cable
000-166-517		Kit, Hydraulic, Single Leica, Includes Valve Assembly, Hoses, Fittings and Solenoid Cable
000-166-407		Kit, Hydraulic, Single MEI/Mikrofyn, Includes Valve Assembly, Hoses, Fittings and Solenoid Cable
000-166-448		Kit, Hydraulic, Single Topcon, Includes System Five Remote, Power and Solenoid Cable (does not include Receiver Cable)
000-166-483		Kit, Hydraulic, Single Trimble GCR, Includes Valve Assembly, Hoses, and Fittings
000-200-148		Kit, Cables, Trimble GCR, Includes Junction Box with Solenoid Cable and Remote, Receiver Cable and Power Cable

---

# TABLE OF CONTENTS

---

MODELS .....	ii
TABLE OF CONTENTS .....	iii
SAFETY INFORMATION .....	v
Safety Precaution Definitions .....	v
WARRANTY .....	vi
LIST OF ILLUSTRATIONS .....	vii
NOTES.....	viii
SYSTEMS FEATURES AND BASIC OPERATION .....	1
Purpose .....	1
Components .....	1
Control Panel .....	2
Rotating Laser .....	2
Laser Receiver .....	2
Cables .....	2
Hydraulic Valve .....	3
Equipment Set-Up .....	4
Job Site Set-Up .....	4
Set-Up for Level Grading.....	4
Set-Up for Sloped Grading.....	5
Benching And Operating .....	7
Benching.....	7
Benching with a Rod Eye.....	7
Operation .....	7
TROUBLESHOOTING.....	9
SPECIFICATIONS AND MAINTENANCE .....	11
Specifications.....	11
Dimensions.....	11
Maintenance.....	12
Storage and Transport.....	12
Cables and Hoses.....	12
Machine .....	12
Calibration .....	12
Service .....	12
NOTES.....	14
REGISTRATION CARD.....	15

---

(This page left blank)

# SAFETY INFORMATION

This manual is furnished to you, the owner/operator, as a guide to get the greatest benefit from your Grading Box. ATI Corporation wants you to be able to get the most use out of your Grading Box through safe and efficient operation.

Before attempting to operate the Grading Box, carefully read all sections of this manual. Be sure that you thoroughly understand all of the safety information and operating procedures.

## SAFETY PRECAUTION DEFINITIONS

**Dangers, Warnings, Cautions, and Notes** are strategically placed throughout this manual to further emphasize the importance of personal safety, qualifications of operating personnel, and proper use of the grading box in its intended application. These precautions supplement and/or complement the safety information decals affixed to the unit and include headings that are defined as follows:

### **DANGER**

**Indicates an imminently hazardous situation which, if not avoided, will result in death or serious injury.**

### **WARNING**

**Indicates a potentially hazardous situation or practice which, if not avoided, could result in death or serious injury.**

### **CAUTION**

**Indicates a potentially hazardous situation or practice which, if not avoided, will result in damage to equipment and/or minor injury.**

*NOTE: Indicates an operating procedure, practice, etc., or portion thereof, which is essential to highlight.*

- Always use caution and safe operating practices when operating this equipment.
- Always set the Automatic/Manual Switch on the Control Panel to MANUAL before leaving the operator's seat or whenever the machine is not moving.

- Always allow for clearance under the cutting edge of the machine when tuning the system or when switching to automatic control. Insufficient clearance could cause the machine to lift itself off the ground as its cutting edge attempts to achieve the programmed slope.
- Never adjust the position of the Laser Receiver when the system is in automatic control.
- Never perform service work on your machine or the Automatic Control System when the system is in automatic control.
- Install all safety panels and guards before operating your equipment.
- Stay clear of all moving parts when the machine is in operation.
- Keep all people clear of the machine when it is running.
- Keep feet and other body parts from under the cutting edges of the machine at all times.
- Read and comply with all safety recommendations of your Tractor/Skid Steer manufacturer, as outlined in its operator and service manuals.

*NOTE: References made to left, right, front, and rear are those directions viewed from behind the power unit and grading box.*

*NOTE: Some equipment depicted in illustrations may not reflect exact production model configurations.*

*NOTE: All safety, operating, and servicing information reflects current production models at the time of publication of this manual.*

*NOTE: ATI Corporation reserves the right to discontinue models at any time, change specifications, and improve design without notice and without incurring obligation on goods previously purchased and to discontinue supplying any part listed, when the demand does not warrant production.*

---

## WARRANTY

---

This Laser Grading Box is designed and manufactured to high quality standards. ATI Corporation, therefore, guarantees this Laser Grading Box to be free from defect in workmanship and materials for three (3) years from purchase date. If the machine is used for rental purposes, the warranty is limited to ninety (90) days.

Laser Controls, Vendored Components and Control Valve Parts are warranted separately by their respective manufacturers.

Does not cover normal wear or failure due to hydraulic oil contamination.

Misuse, abuse, misapplication, and unauthorized alterations will void this warranty.

**All warranty work must be performed by an approved Level Best dealer, and authorized by ATI Corporation.**



---

## LIST OF ILLUSTRATIONS

---

Figure 1. Plane of Laser Light with Components of the Automatic Control System .....	1
Figure 2. Valve Connection Details .....	3
Figure 3. Components of the Automatic Control System .....	3
Figure 4. Method One: Align Rotating Laser with Grade Stakes .....	5
Figure 5. Sight over Rotating Laser .....	5
Figure 6. Grade Stake with Elevation Mark .....	5
Figure 7. Method Two: Align Rotating Laser with Grade Stakes.....	6
Figure 8. Lube and Maintenance Chart.....	13



# SYSTEMS FEATURES AND BASIC OPERATION

## PURPOSE

The Level Best Laser Grading Box is a cost-efficient method for fine grading. Various capacities sized to fit your tractor with a choice of Automatic Control Systems are available.

The Laser Grading Box is intended to operate with an automatic control system providing accurate grade control. If desired, the Laser Grading Box can be operated without an automatic control system in one of two ways:

Without any Valve/Manifold - The cylinder can be connected directly to the tractor and the Laser Grading Box operated using the tractor valve. Flow to the hydraulic cylinder is restricted to improve control. However, movement of the cutting edge can be coarse.

With the Valve and No Control System - A switch can be installed to operate the electric valve from the tractor, providing fine control of cylinder movement. However, raising and lowering of the cutting edge is dependant upon operator attentiveness and accuracy.

For the most accurate control and ease of operation, an automatic control system is used and recommended. This manual is for a tractor-mounted, single cylinder Laser Grading Box with customer-supplied laser controls.

*NOTE: It is the responsibility of the dealer or owner to select, install, and properly operate an automatic control system on this Laser Grading Box within the guidelines of this manual.*

Laser-guided depth control provides unmatched measurement of plane from a single Rotating Laser. Grade information from the Rotating Laser is processed and automatically directs the grading box's hydraulics to maintain the elevation of the cutting edge.

Most automatic control systems can operate automatically or manually.

- In manual control, the operator watches an indicator on the Laser Receiver or Control Panel and uses the box's automatic control system's manual controls to keep the box "On Grade".
- In automatic control, the automatic control system controls the box's hydraulic cylinder to keep the box "On Grade".

## COMPONENTS

Most control systems consist of 4 components:

Rotating Laser – Provides a reference Plane of Laser Light over the entire job site (refer to Figure 1). The Laser Light plane may be level, single-slope, or dual slope to match the slope of the ground.

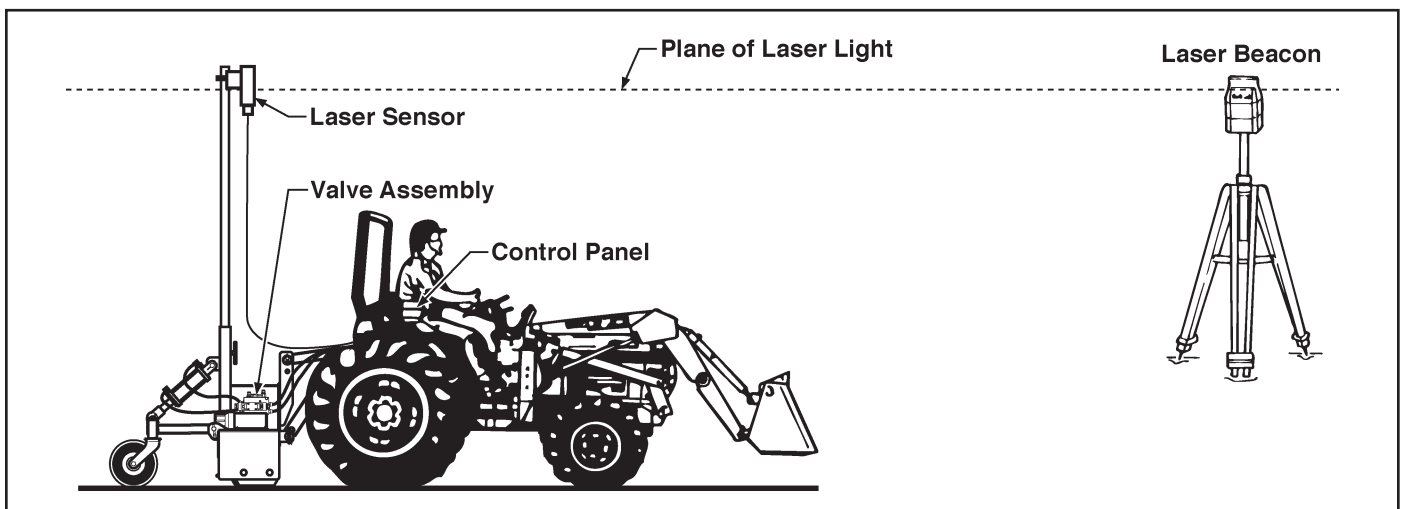

Figure 1. Plane of Laser Light with Components of the Automatic Control System

# SYSTEMS FEATURES AND BASIC OPERATION

Laser Receiver – Mounted at a specific height on a mast on the Laser Grading Box, it determines the difference in depth based on the Plane of Laser Light.

Control Panel – Contains the logic of the automatic control system, processing data from the Laser Receiver and, if equipped, switches controlled by the operator.

Valve Assembly – Wired to the Control Panel, the valve meters hydraulic oil to the hydraulic cylinder for depth control.

## Control Panel

The complexity of the Control Panel varies from system to system. Refer to the specific brand of system for specific details.

## Rotating Laser

The Rotating Laser is the unit that creates a plane of laser light detected by the Laser Receiver. Most Rotating Lasers transmit a focused plane of laser light approximately 1000 feet (300 meters). They are available in single grade, dual grade, and steep slope versions. They can be quickly and easily aligned to job site requirements without complicated calculation of angles.

A dual slope Rotating Laser can be configured for level, single slope, or dual slope applications. Simply enter the required percent of grade and align the Rotating Laser to the axis (direction) to be graded.

- Percent of Grade. The change in elevation for every 100 feet (30 meters) graded.
- Slope. The change in elevation per foot (meter).

## WARNING

**Never look directly into a laser light or serious injury to the eye may occur. In general, incidental exposure of the laser to the eye will not do damage. However, avoid looking into the beam whenever possible. Use a target for viewing the laser spot.**

## WARNING

**Use of any laser on a worksite is controlled by OSHA regulations found at 29 CFR 1926.54. Be familiar with these regulations before using any laser beacon used in conjunction with this system. Review and understand all literature provided with the Laser System before operating.**

## WARNING

**Laser protection devices must be provided to all workers in the area if the laser system exceeds five (5) milliwatts. Refer to the literature provided with the system to determine the power output. If unsure of the strength of the laser system, anti-laser eye protection should be provided to all workers.**

## Laser Receiver

The Laser Receiver detects the laser light generated by Rotating Lasers. The Laser Receiver sends to the Control Panel the location of the plane of laser light. The Control Panel then has the valve assembly drive the Grading Box's hydraulics accordingly. The Laser Receiver is mounted on the mast pole directly above the cutting edge of the box.

## Cables

Cables connect the various components together into a system. A single cable is provided with “open” wires at one end for attachment to the automatic control system or an electric switch. The other end has a 3-pin connector that mates with the hydraulic valve connector.

## CAUTION

**All cables must be secured with adequate cable length to avoid pinching, stretching and tight bending. Do not clamp cables to pipes or hoses that may generate high heat.**

# SYSTEMS FEATURES AND BASIC OPERATION

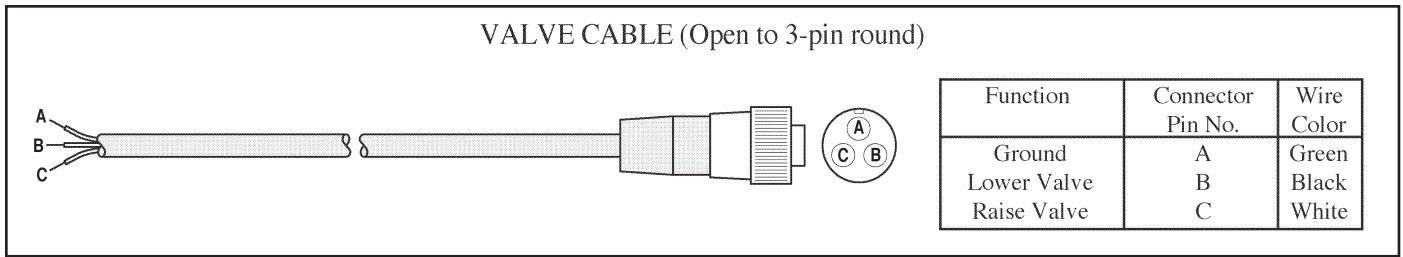

Figure 2. Valve Connection Details

## Hydraulic Valve

The hydraulic valve is mounted on the frame of the Laser Grading Box. It is an electrically-actuated double-acting, single-section valve. Hoses and quick-couplers to attach it the tractor's auxiliary hydraulics are included with the hydraulic kit.

An electrical cable is also provided. One end of the cable has a 3-pin connector for the valve. The other is open and can be attached to the Control Panel of the automatic control system as required. Refer to Figure 2 for wiring details of the cable and conductor functions.

The standard valve accepts a 12 VDC proportional current signal from the Control Panel. If you require a proportional time or 24 volt valve, contact ATI Corporation.

## EQUIPMENT SET-UP

*NOTE: Use these instructions, along with the instructions provided with the automatic control system, as a guide for installing the system on the Laser Grading Box.*

1. Provide power to the Control Panel from the tractor's electrical system. Usually this involves a direct hookup to the battery.
2. Position the Laser Grading Box on a level area for attaching to the tractor. Start the tractor and back up to Laser Grading Box. Attach the unit with the hitch pins supplied.
3. After attaching, ensure the Laser Grading Box is level by adjusting the top link and lower link arms. The front of the Laser Grading Box (closest to tractor) should be

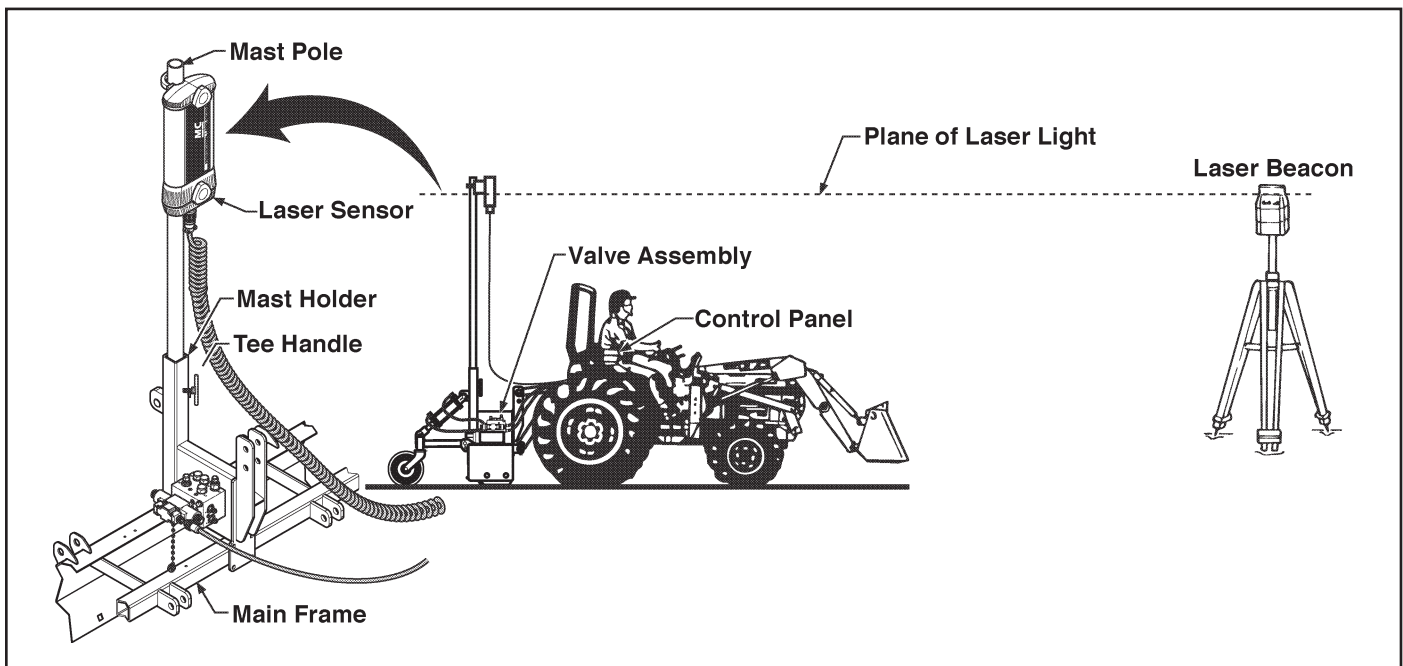

Figure 3. Components of the Automatic Control System

# SYSTEMS FEATURES AND BASIC OPERATION

approximately 1/2" higher than the rear of the Laser Grading Box which should be level with the ground. Turn off tractor.

4. Mount the Control Panel on the right rear fender of the tractor or other easily accessible location.
5. Connect the Laser Grading Box's hydraulic hoses with quick couplers to the tractor quick couplers. The Laser Grading Box's hydraulic manifold is marked with a "P" and a "T" where the pressure and return (tank) hoses enter.

*NOTE: "P" means pressure (supply) and "T" means tank (return). Refer to the Tractor Owner's Manual for identifying the "P" and "T" auxiliary hydraulic ports.*

6. Insert the mast pole into the holder until it rests on the bottom of tube and tighten the tee handle to secure. Clamp the Laser Receiver near the top of the mast so it is higher than any local obstructions including the tractor cab or fall protection devices. (Refer to Figure 3).
7. Connect the various cables to the control system components.
8. If possible, set the automatic control system to manual mode to prevent unintended movement of the Laser Grading Box.

## **WARNING**

**Always have system in MANUAL when not operating the tractor.**

### **JOB SITE SET-UP**

The following are guidelines for setting up a Rotating Laser for both level job sites and sloped job sites:

- Choose a location for the Rotating Laser where obstructions, such as trees and buildings, can not block the plane of laser light. The Laser Receiver needs to be able to sense the plane of laser light at all times.
- Whenever possible, set up the Rotating Laser and the Laser Receiver at a height above the

machine's cab. This prevents the cab or roll-over structure from blocking the plane of laser light as the machine moves around the job sites.

- Be sure the Rotating Laser and Laser Receiver are operating in compatible modes with a head speed that is recognized by the other device.

### **Set-Up for Level Grading**

If the job site is to be level, the set-up of the Rotating Laser is simple. Since no slope is required in either axis, the Rotating Laser does not need to be aligned. The Rotating Laser will provide a level plane of laser light in all directions.

1. Locate the Rotating Laser following the previously stated guidelines.
2. Apply power to the Rotating Laser. Level the Rotating Laser (some Rotating Lasers will automatically level, others will need manual adjustment).
3. Set the counters for both axis at 0.000% (If needed, see the Rotating Laser Operation Manual).
4. Bench the machine. See the "Benching and Operating" procedure in this section.

### **Set-Up for Sloped Grading**

If the job site is to be graded for a single or dual slope, the Rotating Laser requires its axis to be aligned for the job site. The Rotating Laser will then provide a plane of laser light at the required slope(s).

The following procedures are for two typical examples of job sites requiring sloped grades. Remember, each job site is unique, so consider the following methods as guidelines and not as the only methods possible.

#### Method One:

1. Set a minimum of two grade stakes exactly in line with one of the axis to be graded.
2. Place the Rotating Laser in line with the two grade stakes.

# SYSTEMS FEATURES AND BASIC OPERATION

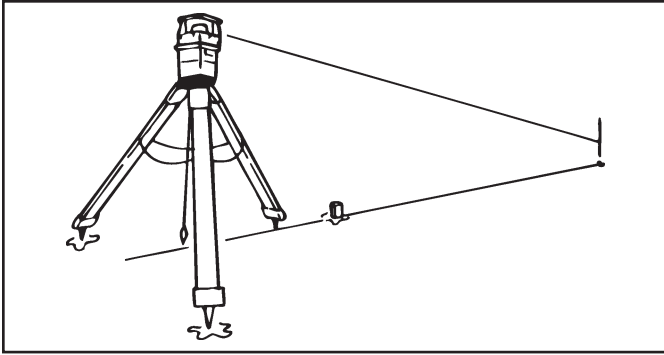

Figure 4. Method One: Align Rotating Laser with Grade Stakes

3. Switch on the Rotating Laser. Level the Rotating Laser (some Rotating Lasers will automatically level, others will need manual adjustment).
4. Set the counter on the Rotating Laser for both axis to 0.0000% (If needed, see the Rotating Laser Operation Manual).
5. Roughly align one of the axis to the grade stakes by sighting over the top of the Rotating Laser (Refer to Figure 5).
6. Align the plane of laser light.
  - a. Set a grade Rod with Rod Eye Receiver on the far grade stake and adjust the rod until the Rod Eye Receiver indicates “On Grade.”
  - b. On the axis not aligned with the stakes, enter on the Rotating Laser: 5.000%. Allow the Rotating Laser to level itself to this new position, if needed.

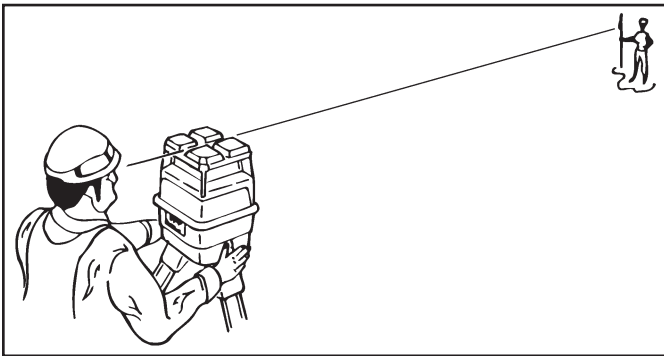

Figure 5. Sight over Rotating Laser

- c. Check the Rod Eye Receiver again.
  - If the Rod Eye Receiver indicates “On Grade”, the plane of laser light is aligned correctly.

- If the Rod Eye Receiver indicates the plane of laser light is too high or too low, have a second person rotate the Rotating Laser on the tripod in small steps until the Rod Eye Receiver indicates “On Grade.”

7. Enter on the Rotating Laser the required percent of grade for each axis and allow the Rotating Laser to level itself again.
8. Bench the machine. See the “Benching and Operating” procedure in this section.

## Method Two:

1. Set a minimum of two surveyed grade stakes. The stakes must have elevation information.

*NOTE: This procedure requires that the elevation of the grade stakes are correct and aligned to the slope or percent of grade required.*

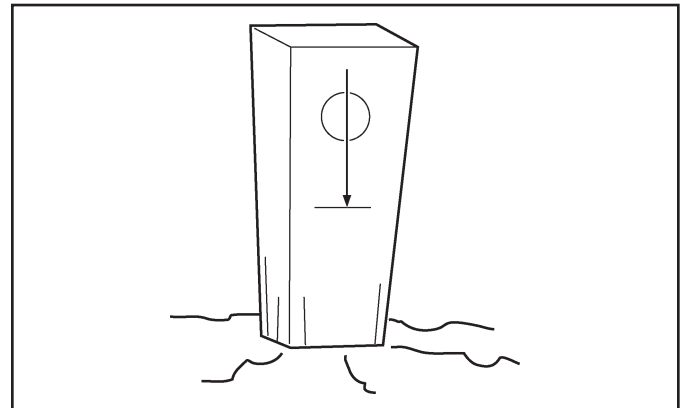

Figure 6. Grade Stake with Elevation Mark

2. Place the Rotating Laser a few feet (meters) behind the first grade stake and in line with one of the far grade stakes (It is not critical to align the Rotating Laser exactly) (Refer to Figure 7).

*NOTE: Follow the guidelines at the beginning of this section when placing the Rotating Laser.*



## SYSTEMS FEATURES AND BASIC OPERATION

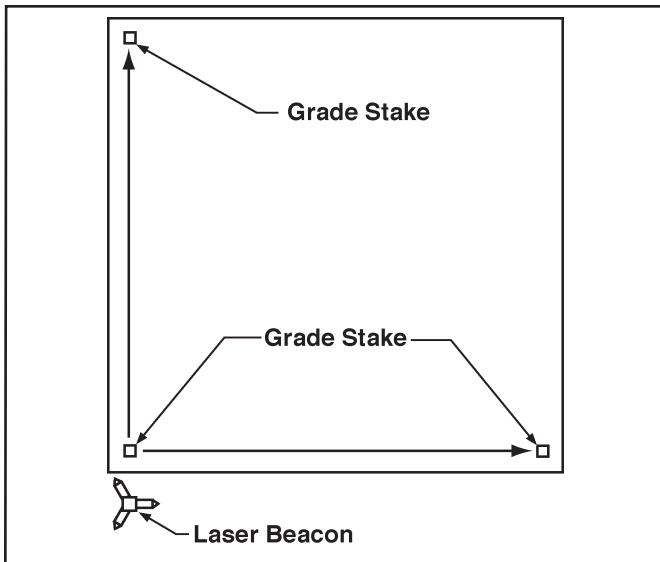

Figure 7. Method Two: Align Rotating Laser with Grade Stakes

3. Switch on the Rotating Laser. Level the Rotating Laser.
4. Roughly align one of the axis to the grade stakes by sighting over the top of the Rotating Laser (Refer to Figure 5).
5. Set both the counters on the Rotating Laser to the required percent of grade (If needed, see the Rotating Laser Operation Manual).

*NOTE: The Grade Rod must be held plumb for each of the readings taken in the following steps.*

6. Establish the H.I. (height of the instrument) for the plane of laser light.
  - a. Align the bottom of the Grade Rod to the mark on the near grade stake.
  - b. Adjust the Rod Eye Receiver up and down until it indicates “On Grade.”
  - c. Adjust the Rod Eye Receiver for any cut or fill amount indicated by the grade stake.
    - If the grade stake shows a cut, extend the Grade Rod and Rod Eye by the amount shown as a cut.
    - If the grade stake shows a fill, lower the Rod Eye by the amount shown as fill.
7. Align the plane of laser light.
  - a. Align the bottom of a Grade Rod to the mark on the far grade stake.

- b. Check the Rod Eye Receiver.
  - If the Rod Eye Receiver indicates “On Grade,” the plane of laser light is aligned at the correct slope.
  - If the Rod Eye Receiver indicates the plane of laser light is too high or too low, have a second person rotate the Rotating Laser on the tripod in small steps until the Rod Eye Receiver indicates “On Grade.”

*NOTE: If it was necessary to rotate the Rotating Laser a significant amount at the far stake, then the original reading at the near stake may be out of tolerance. Check the setting again and make minor adjustments as required.*

8. Bench the machine.

*NOTE: If needed, check the elevations on both the plane of laser light and the grade stake elevations by setting the bottom of the Grade Rod at any stake’s grade mark and checking the Rod Eye Receiver for the “On Grade” indication.*

### BENCHING AND OPERATING

Before benching, the plane of laser light must be set at its proper slope. Benching is the process of setting the relationship between the Laser Receiver and Rotating Laser, or benchmark. Failure to properly bench the system before grading will result in an unacceptable grade.

The goal is to have the Laser Grading Box approximately 1/2 full during operation. If, during rough grading, a lot of material needs to be removed from a site, the Laser Receiver should be set several inches higher than finished grade. As material is removed, the Laser Receiver can be lowered and the site regraded. This may need to be repeated several times until finished grade is achieved.

#### Benching

1. Move the machine to an area which is close to finish grade or, using the manual controls on the control system, grade a small area close to finish grade.



## SYSTEMS FEATURES AND BASIC OPERATION

*NOTE: Finish grade can be checked several times during the grade process to “zero” in on final grade.*

2. If equipped, set the automatic control system to manual.
3. Turn the Laser Receiver and Rotating Laser ON.
4. If equipped, set the deadband tolerance to the minimum possible.

*NOTE: Use narrow deadband for benching.*

5. Adjust the height of the Laser Receiver until it indicates that it is “On Grade”. Loosen the Laser Receiver and raise or lower the Laser Receiver.

*NOTE: Most materials graded must later be compacted. To compensate for the compacting distance, lower the Laser Receiver. This raises the box’s cutting edge by the same distance. The distance the Laser Receiver is lowered depends on the material.*

### **Benching with a Rod Eye**

To bench the Laser Receiver using a Rod Eye, follow the process listed below:

1. Turn on the Rotating Laser. Attach a Rod Eye to a measuring pole and turn on. Set the base of the measuring pole on the benchmark and adjust the measuring pole so the Rod Eye emits a solid “On Grade” tone (compensate for slab thickness and compaction if needed).
2. Find an area to be graded that is close to specified grade. Start the tractor, engage the auxiliary hydraulics and move the unit to that location. Raise or lower the Laser Grading Box’s cutting edge until it is even with the bottom of the measuring pole when the Rod Eye is emitting the “On Grade” tone or resting on the ground if already at grade.
3. Making sure the automatic control system is set to manual and the deadband tolerance is at its minimum, move the Laser Receiver to

a height on the Mast Pole where it indicates the beam is in the “On Grade” position and is unobstructed by any object.

### **Operation**

After the Laser Grading Box is connected and the automatic control system is calibrated, operation can begin.

The operational goal is to drive over the area to be graded with the box 1/2 full of material and the cutting edge On Grade.

1. When seated in the operator’s seat, start the tractor and set the automatic control system to operate in automatic mode.
2. If equipped, set the deadband tolerance to a large value.

*NOTE: Most materials graded must later be compacted. To compensate for the compacting distance, lower the Laser Receiver. This raises the box’s cutting edge by the same distance. The distance the Laser Receiver is lowered will depend on the material.*

## SYSTEMS FEATURES AND BASIC OPERATION

3. Drive the machine forward. The automatic control system constantly senses the plane of laser light, raising and lowering the grading box to maintain the cutting edge at the required elevation. Note the following during operation:
  - In some situations, the system may require a cut deeper than the machine can handle. The machine may lose traction, stall the engine, or the wheel frame will be lifted off the ground to the maximum stroke of the cylinder as the cutting edge tries to reach finished grade. If this occurs, manually raise the cutting edge until the machine can move the material. Make multiple passes to cut the area closer to finished grade and then go back to automatic control. This allows the high spots to be gradually removed.

*NOTE: In rough grading situations, the automatic control system can usually operate as an “Indicate Only” system and the machine controlled manually. After the area is rough graded, return to automatic control.*

4. After several passes with the Laser Grading Box, stop and turn off the tractor. Place the base of the measuring pole on the graded area and check grade elevation.
5. After a rough grade is achieved, reduce the deadband tolerance to meet the job tolerance requirements. With a tighter deadband, the speed of the tractor must be decreased for optimum finish.

# TROUBLESHOOTING

SYMPTOM	POTENTIAL CAUSE	REMEDY
Laser Grading Box does not raise or lower.	Control Panel not turned on.	Apply power.
	No hydraulic flow to Laser Grading Box.	Ensure hydraulic control handle of tractor is in correct position.  Ensure auxiliary hydraulics are ON or in continuous flow mode.
	Cables not connected correctly.	Refer to the automatic control system documentation.  Move directional valve spool manually using the overrides on the end of the directional valve.
		<div style="border: 1px solid black; padding: 5px; display: inline-block;">  <b>WARNING</b> </div> <p><b>Be sure to stay clear of any moving parts of the Laser Grading Box.</b></p> <p>If the Laser Grading Box moves, refer to Electrical problems. If the Laser Grading Box does not move, refer to Hydraulic problems.</p>
	Electrical Problems	Refer to the automatic control system documentation.  Check the Solenoid Cable and directional valve for visible damage.
	Hydraulic problems.	Confirm hydraulic flow through the manifold and returning to the power source through the “T” hose.  Contact ATI Corporation for help troubleshooting the hydraulic manifold.
Laser Grading Box moves in opposite direction.	Hydraulic flow reversed.	Confirm the pressure is going in the “P” port.  Verify control handle is moving in desired direction.

## TROUBLESHOOTING

SYMPTOM	POTENTIAL CAUSE	REMEDY
Box has trouble staying on grade.	Rotating Laser out of range.	Ensure Laser Receiver is within specified operating range of Rotating Laser.
	Laser beam being reflected.	Ensure Rotating Laser's light is not reflecting off other surfaces (windows, windshields, mirrors, etc.) causing multiple readings by the Laser Receiver.
	Multiple laser beams.	Ensure that there are no other lasers operating on the job site or nearby.
	Laser deadband set too narrow.	Ensure the deadband tolerance is set for rough grading.
	Travel speed is too fast for grade tolerance.	Slow down.
	Hydraulic response too quick.	Decrease the Gain Selection Switch setting.
	Hydraulic flow reversed.	Confirm the pressure is going in the "P" port.

# SPECIFICATIONS AND MAINTENANCE

## SPECIFICATIONS

### Dimensions

<b>Model</b>	<b>SC48</b>	<b>SC54</b>	<b>SC60</b>	<b>SC66</b>	<b>SC72</b>
Box Width	48 in. (123 cm)	54 in. (138 cm)	60 in. (152 cm)	66 in. (168 cm)	72 in. (183 cm)
Overall Width	50 in. (127 cm)	56 in. (142 cm)	62 in. (157 cm)	68 in. (172 cm)	74 in. (188 cm)
Total Length	42.4 in. (108 cm) 76.4 in. (194 cm) with optional drawbar				
Box Capacity	4.1 ft <sup>3</sup> (0.11 m <sup>3</sup> )	4.6 ft <sup>3</sup> (0.13 m <sup>3</sup> )	5.1 ft <sup>3</sup> (0.14 m <sup>3</sup> )	5.6 ft <sup>3</sup> (0.16 m <sup>3</sup> )	6.1 ft <sup>3</sup> (0.17 m <sup>3</sup> )
Weight	345 lbs. (156 kg)	365 lbs. (166 kg)	395 lbs. (179 kg)	410 lbs. (186 kg)	425 lbs. (193 kg)

# SPECIFICATIONS AND MAINTENANCE

## MAINTENANCE

The rugged and durable Laser Grading Box is built to last but, as with all equipment, a few minutes of routine care, maintenance, and cleaning can extend the life of the system.

### Storage and Transport

Most often the Laser Grading Box and its hydraulic controls remain on the machine. However, the Control Panel, Laser Receiver, and cables should be stored in a safe place when not in use. Protect the cable connections by installing any covers supplied.

### Cables and Hoses

Check all cables and hoses regularly for signs of wear and damage. Keep cable connections clean and free from dirt and corrosion. If a cable has been damaged, do not attempt to repair. Incorrect or poor connections can cause damage to your automatic control system.

When applicable, check the hydraulic hoses. Look for areas where the hoses could rub against each other or another object as they expand and contract under pressure. Check the hydraulic fittings for tightness.

### Machine

Check areas that affect the automatic control system function and accuracy, such as looseness or play in the cylinders or wear on the box's cutting edge. Looseness in the connection to the tractor/skid steer, such as in the 3-point hitch/adaptor plate, will cause inaccurate depth positioning.

Also check the tractor/skid steer routinely for wear to its components, such as the loader pins and 3-point linkage, ensuring it is operating properly.

## Calibration

Perform periodic calibration checks of the Rotating Laser System, as outlined in its Operation Manual, to ensure accurate performance.

## SERVICE

If the automatic control system is not functioning properly, the first step is to determine the problem component. Use the Troubleshooting Chart to determine possible causes and remedies.

### CAUTION

**The Automatic Control System is a highly sophisticated electronic system. Do not attempt repairs to the components. Contact your local dealer if you have any problems.**

# SPECIFICATIONS AND MAINTENANCE

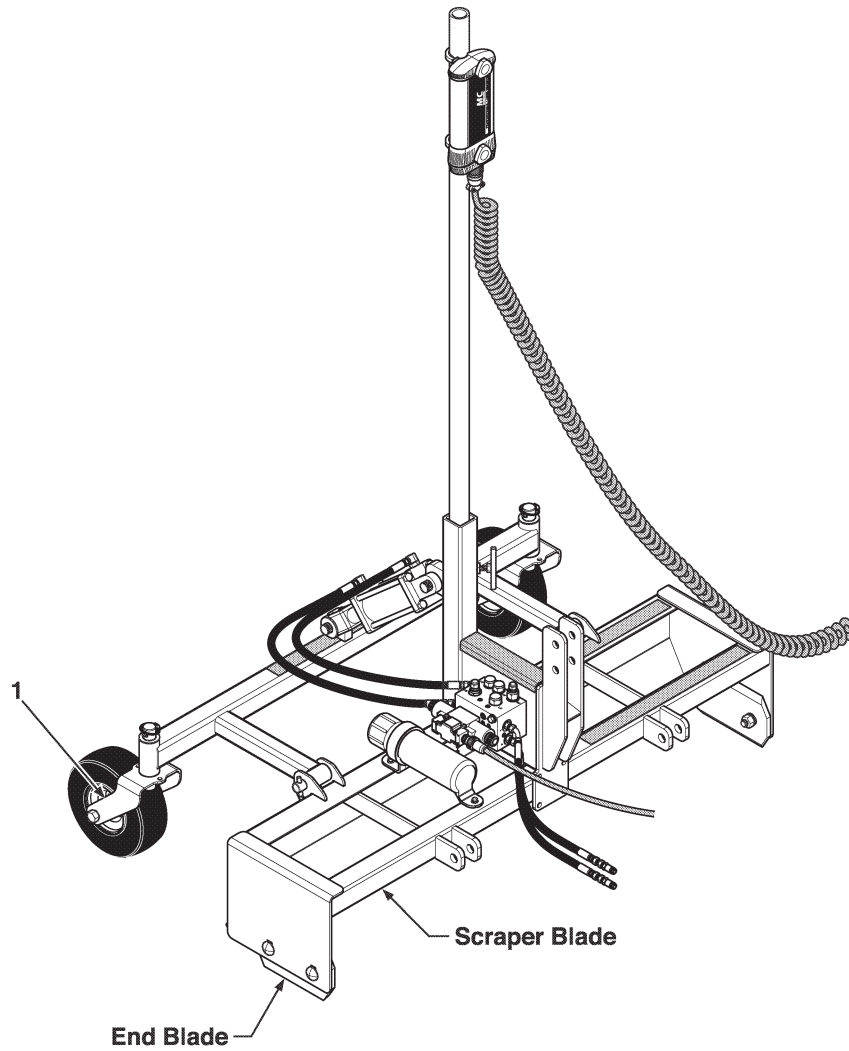

ITEM	NAME	FREQUENCY	LUBE TYPE
1.	Wheel Hub (2)	Annually	EP*
* EP - Multi-Purpose Grease.			

**NOTES:**

1. Check Hydraulic System Components for wear and/or leaks.
2. Check and tighten all bolts and nuts for scraper blade and end blades, weekly.

Figure 8. Lube and Maintenance Chart





# REGISTRATION CARD

**By buying this product, you, the purchaser of this product, agree to the following:**

To the fullest extent permitted by law, the purchaser of this product shall indemnify and hold harmless ATI Corporation and its authorized dealer from and against claims, damages, losses and expenses, including but not limited to attorney's fees, arising out of or resulting from the use of the product, provided that such claim, damage, loss or expense is attributable to bodily injury, sickness, disease or death, or to injury to or destruction of tangible property, but only to the extent caused by the negligent acts or omissions (Including but not limited to misuse or alteration of the product) of the purchaser, anyone directly or indirectly employed by the purchaser or anyone for whose acts the purchaser may be liable, regardless of whether or not such claim, damage, loss or expense is caused in part by a party indemnified hereunder.

In claims against any person or entity indemnified under this agreement by an employee of the purchaser, anyone directly or indirectly employed by the purchaser or anyone for whose acts the purchaser may be liable, the indemnification obligations shall not be limited by a limitation on amount or type of damages, compensation or benefits payable by or for the purchaser under worker's compensation acts, disability benefit acts or other employee benefit acts.

## CUSTOMER COPY

Dealer \_\_\_\_\_ Date Installed \_\_\_\_\_  
Grading Box Model # \_\_\_\_\_ Serial # \_\_\_\_\_  
Control Panel Model # \_\_\_\_\_ Serial # \_\_\_\_\_  
Laser Receiver Model # \_\_\_\_\_ Serial # \_\_\_\_\_  
Dealer Name \_\_\_\_\_  
Street \_\_\_\_\_  
City, State, Zip \_\_\_\_\_  
Telephone \_\_\_\_\_ Fax \_\_\_\_\_  
Signature \_\_\_\_\_

DETACH AND MAIL TO ATI CORPORATION • 250 EARLAND DRIVE • NEW HOLLAND, PA 17557  
or FAX to (717) 354-2162



## MANUFACTURER'S COPY

Dealer \_\_\_\_\_ Date Installed \_\_\_\_\_  
Grading Box Model # \_\_\_\_\_ Serial # \_\_\_\_\_  
Control Panel Model # \_\_\_\_\_ Serial # \_\_\_\_\_  
Laser Receiver Model # \_\_\_\_\_ Serial # \_\_\_\_\_  
Customer Name \_\_\_\_\_  
Street \_\_\_\_\_  
City, State, Zip \_\_\_\_\_  
Telephone \_\_\_\_\_ Fax \_\_\_\_\_  
Signature \_\_\_\_\_